

# Light Scattering Particulate Emission Monitor

PROCESS & EMISSIONS MONITORING SYSTEMS



patent pending

## SPECIFIC FEATURES:

- *ProScatter*<sup>™</sup> Backscatter sensor technology with superior minimum detection <1mg/m<sup>3</sup>
- Certified to 15 mg/m<sup>3</sup> for processes with low typical emission limits
- Manual and remote Zero and Span (reference) checks available to ensure optimal instrument performance and to comply with EN 13284/QAL1
- Automatic Functionality Check - fully interrogates the optical system
- Purge Flow Fail Sensor option with inbuilt automatic optical shield activation

COMPLIANCE WITH:  
**EN 13284**



THE QUEEN'S AWARDS  
 FOR ENTERPRISE  
 2017



Tested AMS  
 Regular  
 Surveillance

www.tuv.com  
 ID 0000053807



Sira MC 160307/01

# TECHNOLOGY / APPLICATION

## SYSTEM DESCRIPTION

PCME's QAL 260 sensor series is suitable for measuring dust concentrations in Incineration, Combustion and other industrial stacks and is compliant with EN 14181. Having a 0-15 mg/m<sup>3</sup> certification range, the QAL 260 sensor can be used at low or high dust levels. Due to dynamic ranging the sensor is also suitable for much higher dust levels found in Power, Cement and Metals smelting processes.

Conveniently mounted on one side of the stack, with no secondary light absorber or beam dump requirement, the QAL 260 series is non-intrusive and has no measurement components protruding into the stack, so process gases are not disturbed. As critical optical components remain outside the stack, the risk of contamination is reduced. Contamination reduction is managed by an optical shield\*, which is automatically activated when the Purge air flow greatly reduces or fails.

In addition, a Flue gas blocker can be fitted to ensure any flue gases do not escape when the unit is opened for auditing or maintenance purposes.

The QAL 260 is ideal for medium to larger stacks that require high accuracy, low maintenance, flexible system configuration and compliance with International Standards. As an alternative to opacity monitors, the QAL 260 offers a more reliable PM dust measurement as it is calibrated as a PM monitor (and not as a smoke or opacity monitor), where emissions are to be reported in mg/m<sup>3</sup> and early indication of increased dust emissions is required at lower dust concentrations.

\*patent pending

## PRINCIPLE OF OPERATION

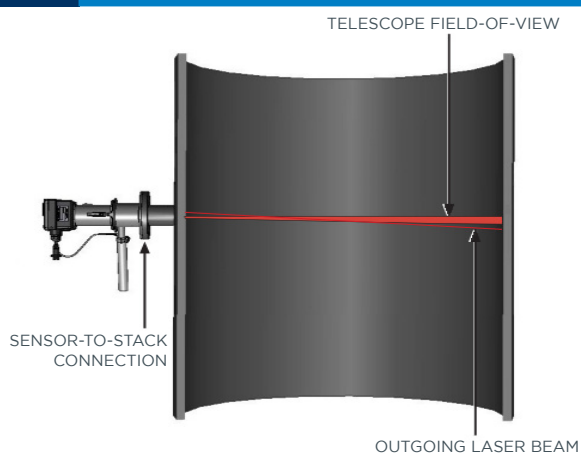

The PCME QAL 260 is based on ENVEA UK's class leading *ProScatter*<sup>™</sup> Backscatter technology. Particles in the stack are illuminated by a laser and the amount of laser light scattered back from the particles is measured by a detector. Stray scattering and ambient light are eliminated by tuning the instrument's field-of-view and by use of a modulated laser source.

The instrument response is proportional to dust concentration. It is calibrated to provide a mg/m<sup>3</sup> measurement by comparison to results of a standard reference (isokinetic) test.

The PCME QAL 260 sensor is able to measure dust levels of less than 1 mg/m<sup>3</sup>, and so can be used in applications where emissions are well below the sensitivity limit of traditional opacity instruments.

## TYPICAL USE AND APPLICATIONS

The PCME QAL 260 is well-suited for use in medium to larger stacks and is suitable for low to high dust concentration measurements, regardless of dust velocity or charge.

It is a reliable alternative to Opacity in power plant and

combustion applications, where emissions are to be reported in mg/m<sup>3</sup> and early indication of increases in dust emissions is required.

## COMPLIANCE AND QUALITY ASSURANCE

To comply with EN 14181, the PCME QAL 260 is supported with optional manual reference materials (audit unit or filters) for convenient linearity and functionality tests that are required at the time of the QAL 2 and Annual Surveillance Test (AST) or drift and calibration Relative Accuracy Test Audit (RATA) tests.

The automatic contamination check system (patent pending) ensures that any optical variances are measured, defined and adjusted to ensure zero and span drift is kept to a minimum.



PCME QAL 260 shown with a multi-value Manual Audit Unit and attenuator

# PRODUCT FEATURES

## STANDALONE SENSOR OR MULTI-SENSOR SYSTEM OPTIONS

The sensor is available as a standalone version, the compact PCME QAL 260c, or the PCME QAL 260s, which is combined with a control unit to provide either a standard, single-channel system or a multi-channel PRO system for an extensible network (for up to 32 sensors).

Using a Multiple-Sensor System based on a ProController allows other sensors from the range to be added (including Gas Flow, Temperature and Pressure sensors) for Mass Emissions Monitoring, Bagfilter Management (using ENVEA UK's Baghouse Performance sensors) or as part of a CEM system, including gas analysers.

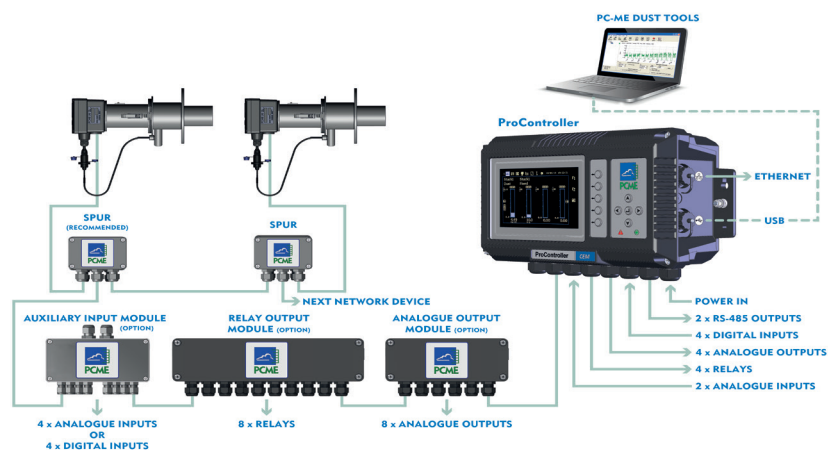

PCME QAL 260s sensors used in a network system

## CONTROL UNITS

The PCME QAL 260s PRO system is powered by the ProController, which provides central communications for analysing emissions data and trends, compliance reporting as well as data recording for plant networks with multiple sensors (up to 32) and links the sensors into data acquisition systems (DAHS/DCS).

Alternatively, the PCME QAL 260s Standard system is for simple, single-sensor systems and is powered by the Standard Controller.



ProController



Standard Controller

PCME QAL 260s	ProController	Standard Controller
<b>Performance Specifications</b>		
Number of Sensors/Channels	1-32	1
Display	High-contrast, anti-glare 7" (viewable) TFT LCD	Two-tone grey, backlit graphical LCD
Screen Resolution	800 x 480 pixels, WVGA	320 x 240 pixels
Network Modules	Suitable for use with all ENVEA UK network modules	n/a
<b>Electrical Specifications</b>		
Power Supply Voltage	85-265 V AC (50/60 Hz)	100-240 V AC (50/60 Hz)
Standard I/O*	1x RS-485 (Modbus RTU) 4x Relay outputs (3A @ 250 V AC/24V DC, configurable) 4x 4-20mA outputs (500 Ω) 4x Digital inputs (voltage free) 2x 4-20mA inputs	1x RS-485 (Modbus RTU) 2x Relay outputs (2A @ 250 V, configurable) 1x 4-20mA output (isolated, 500 Ω) 2x Digital inputs (for Plant OFF indication)
Advanced I/O	Ethernet (100 Mb/s) USB 2.0	none
Network Modules (optional)	<b>Auxiliary Input Module (AIM):</b> 4x 4-20 mA (500 Ω) inputs or 4x Digital inputs <b>Analog Output Module (AOM):</b> 8x 4-20 mA outputs (500 Ω) <b>Relay Output Module (ROM):</b> 8x Relays (1A @ 250 V)	n/a
<b>Operating Specifications</b>		
Protection Rating	IP66	IP65
Ambient Temperature	-20°C to 50°C	-20°C to 50°C
<b>Mechanical Specifications</b>		
Weight	5.7 kg	1.6 kg
Enclosure Dimensions	W 390 x H 221 x D 118 mm	W 220 x H 124 x D 80 mm

\* in addition to the sensor outputs

# SPECIFICATIONS

# PCME QAL 260

## PROCESS/APPLICATION CONDITIONS

Application Suitability	Suitable for measurement in non-condensing flue gases	
Location Suitability	This equipment is for outdoor or sheltered use; safe for use in an ambient temperature of -20 to 50°C (-4°F to 122°F)	
Flue Gas Temperature (at monitoring point)	-20°C to 250°C (-4°F to 482°F) option: up to 400°C (752°F)	
Stack Pressure	±20 mbarg	
Stack Diameter*	1-10 m (3.3-33 ft.)	*application specific
Flue Gas Composition	Non-condensing	
Hazardous Zone Classification**	Zone 2	**pending
Stack Connections	<ul style="list-style-type: none"> <li>3" 150 lb ANSI flange</li> <li>DN80 PN10/PN16 flanges</li> <li>JIS 100-5k, -10k flanges</li> </ul>	

## MEASUREMENT INFORMATION

Measurement Type	Light scattering
Resolution	0.1 mg
Response Time	2 seconds
Certification Range	0-15 mg/m <sup>3</sup>
Dust Levels	<1 to 500 mg/m <sup>3</sup>

## PURGE OPTIONS

		QAL 260c	QAL 260s
Blower (medium)	Purge Blower	option	option

## SENSOR OPTIONS

Sensor Variants	PCME QAL 260c - compact standalone PCME QAL 260s - with a Standard Controller or a ProController
Sensor Material	316 Stainless Steel
Sensor Dimensions	L 454 x H 217 x D 204 mm, incl. flange (18 x 8.5 x 8 in.)
Zero/Span Sensor Checks	Manual and remote initiation of inbuilt check mechanism
Protection Rating	IP65
Power Supply Voltage	100-240V AC or 24V DC (via control unit or from local source)
I/O	1x RS-485 Modbus, 2x Relay outputs 1x 4-20 mA output, 1x Digital input
Manual Audit Capability	Single, compact unit or manual unit with 5 attenuators
Air Purge Flow Sensor	Option, standard for high-temperature sensors
Filter Display Module (FDM)	Remote display unit (option)

## NETWORK MODULES (available only with the PCME QAL 260s)

		PCME QAL 260s Standard or PRO network systems
AOM	Analogue Output Module: 8x 4-20 mA	Option
ROM	Relay Output Module: 8x Relays	Option
AIM	Auxiliary Input Module: 4x 4-20 mA or 4x digital inputs	Option
Network Spur	For 'spur-linked' sensor networks	Option
Interconnecting Cable	From sensor to control unit	10m supplied as standard, max. length 500m

## PC-ME DUST TOOLS SOFTWARE

PC-ME DUST TOOLS is a powerful and customisable software suite for downloading, displaying, analysing and reporting data from the control units and sensors to PCs, enabling ease of access to emissions data from plant-wide sources.	
<b>PCME QAL 260c</b>	
Device Set	Configuration of settings in standalone sensor devices with integrated user setup and display
Online	Access to real-time data from both control units and standalone integrated sensor systems
Predict	Analysis tool for the location of failing and faulty bag-filter media before gross filter failure occurs
<b>PCME QAL 260s</b>	
Predict View	Full Predict module functionality for real-time and historical logged data
System Set	Full configuration of advanced systems and convenient access to control unit settings for multi-channel networked systems
Data Downloader	Automatic data transfer at configurable, timed intervals
Auto Download	Automated downloading between control units and PCs
Data Viewer	Instantaneous and long-term trend analysis of emissions data

Note: for detailed information relating to product options and ordering, please consult the Specification Guide, available on request from ENVEA UK.

## ABOUT ENVEA UK

As a progressive environmental Company, ENVEA UK specialises in particulate measurement for industrial processes. With a worldwide reputation for reliability, innovation and technological excellence, the Company produces under the trademark envea™ equipment for concentration and mass monitoring for regulatory, environmental and process control requirements. A dedicated team of qualified application and sales engineers is always on hand and should be consulted in the selection and usage of the most suitable equipment for any particulate application.



ENVEA UK  
ENVEA House Rose and Crown Road  
Swavesey / Cambridge - UK CB24 4RB  
☎ +44 (0)1480 468200  
✉ contact.gb@envea.global

Part of the ENVEA Group



www.envea.global